

F18AKL02XX *Range Family*

Crutch support bracket, this crutch support bracket is a very important accessory for people washing from the sitting position who require something to hold a crutch or walking stick. This can be fitted to either end of the rail.

Physical data

Dimensions (mm.)	133x95,5x34
Weight (kg.)	0,160

Delivery methods

Package	LDPE bag in cardboard box
Package dimensions (mm.)	160x170x43
Weight with Packaging (kg.)	0,210

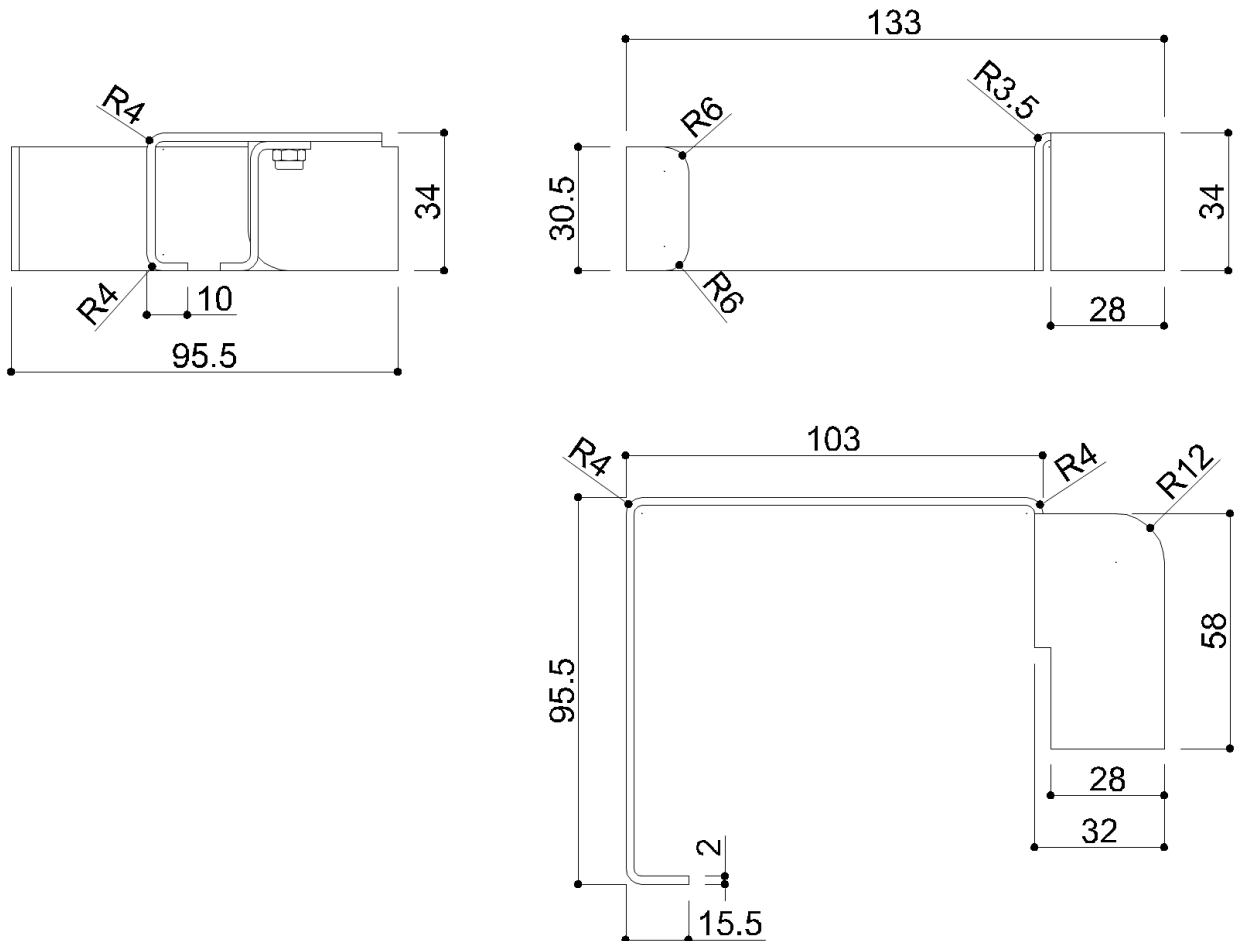

F18AKL02XX *Range Family*

Available colors

D8	W2
 Oxide Grey	 Warm white

Materials and finishes

Stainless steel	Polished
-----------------	----------

Safety tips

Before installing and using the device, read the instructions for use and especially the safety warnings carefully and follow them.
If in doubt, contact the company before using the device.

Information on use

The device is not affected by the room's temperature, though it must NOT be installed in environments subject to temperatures below 4°C or above 40°C.
Do not install in saunas. Not comply with the indicated temperatures may damage the plastic coating of the device.

Warranty

If this product fails due to a defect in material or workmanship during the time of periods listed below for each product, Ponte Giulio will replace or repair it free of charge. .
Warranty 2 YEARS